

INTRODUCING EPPUR DREEFT

DISTRIBUTED BY



Sales contacts

Germany

info@deconmobility.de
+49 (0) 3222 18 52 896

Netherlands

info@mobilityproducts.nl
+31 (0)85 - 87 86 144

Scandinavia

sales@decon.se
+46 (0) 34540880

_DREEFT

DO YOU WANT TO BRAKE FREE ?



EPPUR



MADE IN
FRANCE

SLOW DOWN

The first braking device for manual wheelchairs
A SET OF WHEELS TO SLOW DOWN WITH NO PAIN



Today, braking or turning a wheelchair implies using your hands as brake pads, causing shoulder pain and hand burns. Thanks to Dreeft wheels, brake with your fingertips with no effort or friction!

Just lightly pull the handrim backwards to activate the coaster brake system.



GO FURTHER

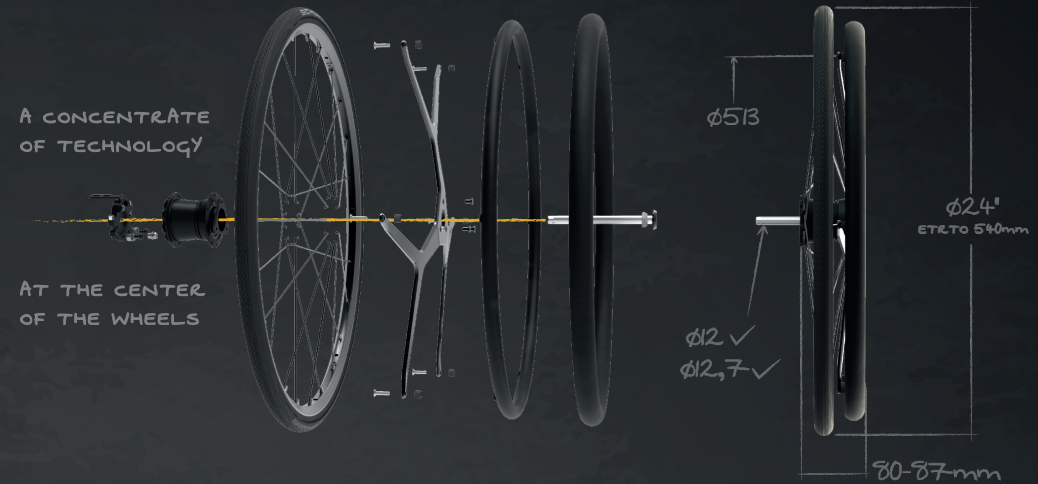

TECHNICAL DATASHEET		Spokes :	24 spokes 14G black steel
Wheel dimensions :	24" (ETRTO 540mm)	Handrim fixation part :	Black powder coated aluminium
Tyres :	Schwalbe Marathon+ 25-540	Quick release axis diameter :	Compatible with 12mm & 12,7mm
Handrims :	Black anodized aluminium $\phi 19$ mm	Handrim-to-rim spacing :	12mm or 19mm
Rims :	Double wall, aluminium	Max user weight :	120 kg
Handrim grip :	PVC rubber hand grip $\phi 30$ mm	Fully equipped wheel weight :	3 750 g



Zero friction

Say goodbye to gloves and hand burns



80% Less effort

Compared to standard wheels (Your shoulders will say thank you)



Motorizable

Helps you steer with rear power assist. No pain, no danger !



Appropriate for para & quadri

Usable without hand gripping, even under the rain !