

# Instructions for use

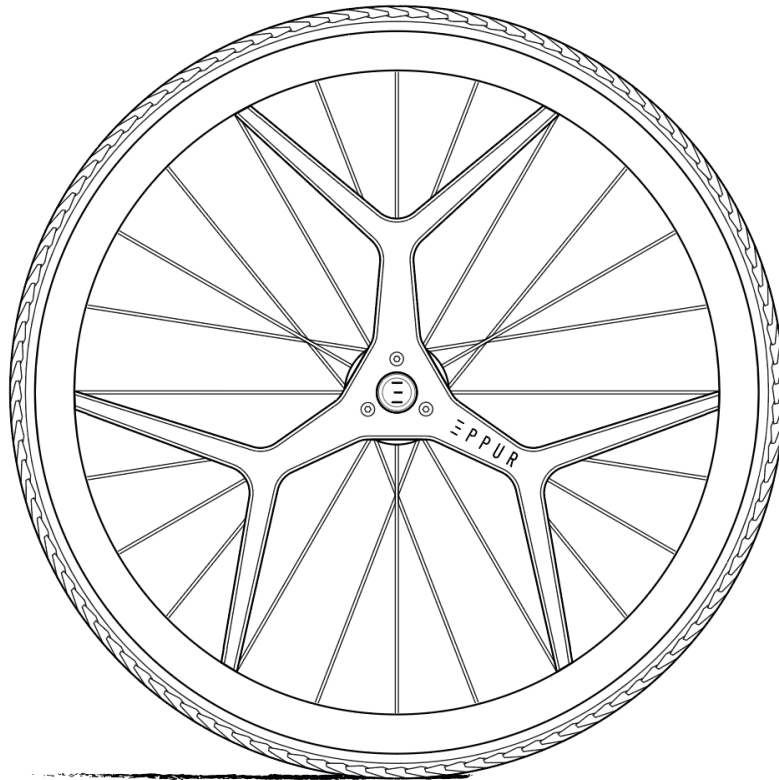





*DREEFT by Eppur*



*This product complies with Regulation (EU) 2017/745 relating to medical devices. The CE declaration of conformity includes the date of placing the device on the market.*

*Manufacturer: Eppur SAS, 70 rue du Docteur Yersin, 59120 Loos  
Company registration: 88178940800013  
VAT number: FR47881789408  
Email address: [hello@eppur.eu](mailto:hello@eppur.eu)*

**CONTENTS** 

<b>I. GENERAL</b> 	<b>4</b>
1) Information about the user manual	4
2) CE conformity	4
3) Warranty and Disclaimer	4
4) Intended use	5
<b>II. PRODUCT DESCRIPTION</b> 	<b>5</b>
1) Operation	5
2) General information	5
3) Technical data	6
1. Dimensions and weights of Dreeft wheels	6
2. Environmental conditions	6
3. Materials	6
4. Identification label	7
4) Wheel components	7
1. Overview	7
2. Components	8
<b>III. USE OF DREEFT WHEELS</b> 	<b>8</b>
1) Assembly and disassembly of wheels	8
1. Compatibility of Dreeft wheels with wheelchairs	8
2. Propulsion and braking	9
3. Assembly and disassembly of Dreeft wheels	9
4. Installation of other wheel models once the wheelchair is fitted with adapters	10
2) Use of the wheels	10
1. Safety information	10
2. First trips with a wheelchair equipped with Dreeft wheels	10
3) Maintenance of11	11
4) Transporting wheels	11
<b>IV. SAFETY</b> 	<b>Meaning</b>
1) of warning symbols	11
2) General safety information before using wheels	11
3) General safety information when using wheels	12
4) General safety information when mountingwheels	13
<b>V. MAINTENANCE</b> 	<b>13</b>
1) Safety information	13
2) Maintenance	14
3) Fault identification and repair	14
<b>VI. AFTER USE</b> 	<b>14</b>
1) Disposal	14
<b>VII. NOTES</b>	<b>15</b>

## I. GENERAL

### 1) **User manual information**

Before using Dreeft wheels, read this manual and save - it for the entire duration of use of the wheels to consult it later if necessary. Please follow all safety instructions to avoid injury and product damage.

This manual **MUST** be provided to the user of the product.

It is strictly forbidden to dismantle the wheel hubs yourself without the specific agreement of the Eppur brand, otherwise the warranty will be voided.

In the event of dismantling, the user is exposed to the risk of losing control of the wheelchair and of falling.

You can find the PDF file of this document on the website: [eppur.eu](http://eppur.eu). The PDF file can also be displayed in an enlarged format.

For any further information concerning these instructions for use, do not hesitate to contact the specialized personnel who provided you with the product or the manufacturer.

### 2) **CE**

compliance Dreeft wheels meet the requirements of Regulation (EU) 2017/745 relating to medical devices. According to appendix VIII of this regulation, the Dreeft wheelset has been classified in class I based on the classification criteria of the regulation. The declaration of conformity has been issued by the manufacturer under his own responsibility.

### 3) **Warranty and Limitation of Liability**

The manufacturer's legal warranty for non-conformity is 2 years from receipt of the product under normal of the device.

Wear components are not affected by the legal guarantee of non-conformity since they wear out in normal use of the product:

- Tires
- Inner tubes
- Grip coatings on handrails

The manufacturer is responsible in the event of non-conformity if the product is used according to the descriptions and instructions in this leaflet. In the event of damage due to non-compliant use of the terms of use present in this document, the manufacturer declines all responsibility.

Warranty claims can only be made to the supplier from whom the product was obtained.

#### 4) **Intended Use**

Before using this product, familiarize yourself with its handling, operation, and use to avoid mishaps and injuries.

Please observe the following points:

- Users and their carers must be instructed in the use of Dreeft wheels by specialist personnel using these instructions for use.
- Maintenance and repairs may only be carried out by specialized personnel. In the event of a problem, contact the supplier who provided the product.
- Eppur reserves the right to make technical changes relating to the version described in these instructions for use.

## II. **PRODUCT DESCRIPTION**

### 1) **Operation**

wheels are intended for autonomous or accompanied movement of people with partial or total lower limb disabilities.

The wheels can be used both outdoors and indoors on stable ground.

### 2) **General information**

<i>Description of Dreeft wheels</i>	Dreeft is a pair of wheels for wheelchairs integrating a so-called "backpedalling" braking system. The hub of each wheel includes a braking system controllable by the handrail. The pair of wheels is attached to the frame of the chair using an interface included in the installation kit.
<i>Destination of Dreeft wheels</i>	Dreeft allows users of manual wheelchairs to brake, turn and slow down with reduced effort on the upper limbs and without friction on the hands.
<i>Indications</i>	Users of manual wheelchairs equipped with 24 inch wheels with considerable or complete impairment of mobility due to structural and/or functional damage to the lower extremities and possessing sufficient strength and gripping function of the arms and hands to propel the wheelchair rolling.
<i>Contraindications</i>	Users who cannot propel themselves independently on a manual wheelchair, hemiplegic users.
<i>Users:</i>	Manual wheelchair users.

### 3) **Technical data**

### 1. Dimensions and weights of Dreeft wheels

<i>Weight of wheelset</i>	7.6 kg
<i>Weight of one wheel</i>	3.78 kg
<i>Dimension of a</i>	24 inch wheel_ETRTO: 25-540mm

### 2. conditions Environmental

wheels should:

- be kept protected from humidity;
- not be exposed to extreme temperatures (e.g. extreme cold, sauna, solar radiation, etc.);
- not to be used in salt water;
- be protected from sand or any other dust/dirt particles which may affect the use of the wheels and the brake function.

### 3. Materials

<i>Rim</i>	Aluminum
<i>Spokes</i>	Steel
<i>Hub</i>	Steel
<i>Handrim</i>	coating
<i>Handrim</i>	Aluminum Handrim Aluminum
<i>PVC</i>	Polmerplast A-70
<i>Pneumatic</i>	Rubber
<i>Quick</i>	Steel and aluminum

#### 4. Identification label

A medical device identification label is stuck on the inner part of the aluminum flanges.



- |  |   |
|--|---|
| <ol style="list-style-type: none"> <li>1. Manufacturer's address</li> <li>2. Trade</li> <li>3. reference</li> <li>4. Date of manufacture</li> <li>5. Fragile product</li> <li>6. Do not use if the packaging is defective</li> </ol> | <ol style="list-style-type: none"> <li>7. Read the instructions before use</li> <li>8. CE marked product</li> <li>9. UDI traceability number read as follows:           <ul style="list-style-type: none"> <li>(01) MANUFACTURER CODE</li> <li>(11) DATE OF MANUFACTURE<br/>YYMMDD</li> <li>(21) SERIAL NUMBER</li> </ul> </li> </ol> |
|--|---|

#### 4) Wheel Components

##### 1. Overview

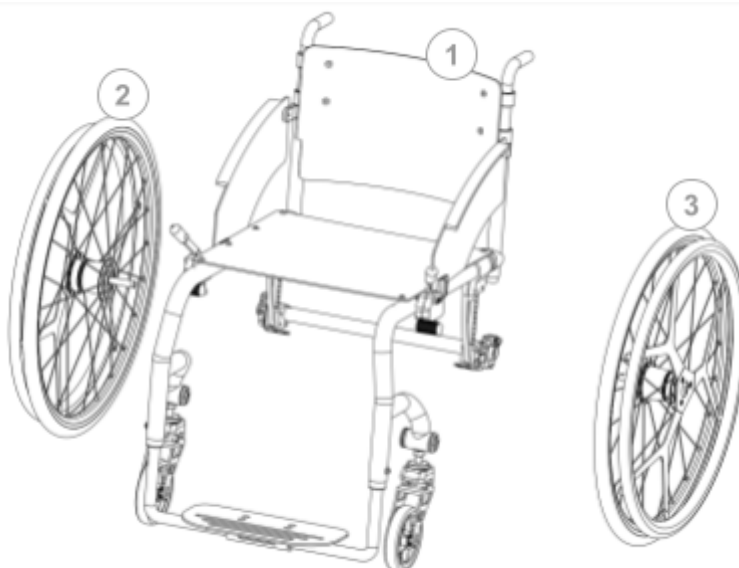

1. Wheelchair Frame
2. Right
3. Wheel Left Wheel

## 2. Components

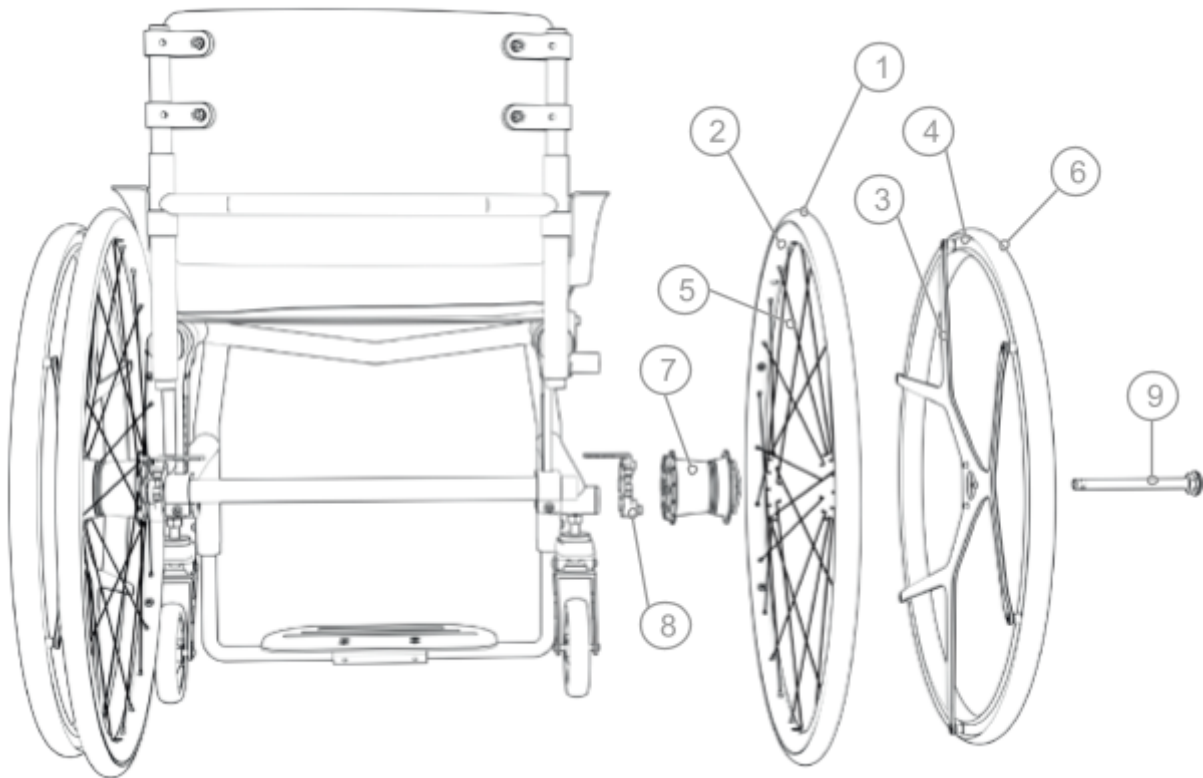

- |            |  |
|------------|--|
| 1. Tires   | 6.  |
| 2. Rim     | 7. Hub   |
| 3. Wheel   | 8. Adapter   |
| 4. Handrim | 9. Quick   |
| 5. Handrim |  |

## III. WHEELS *Axle*

### 1) Mounting and removal of wheels

#### 1. Compatibility of Dreeft wheels with wheelchairs

The pair of Dreeft wheels is delivered with several components:

- 2 adapters: the interface attached to the wheelchair making it compatible with Dreeft wheels.
- 2 quick axles: Allowing the wheels to be assembled on the frame without tools

The adapter and the axle must be adapted to the wheelchair on which the wheels are mounted.

**⚠ If an axis or an adapter is not suitable for the chair model, stop using it and contact the supplier who distributed the product.**

The distributor supplying the wheels should ensure that they supply an adapter reference that is compatible with your wheelchair. In case of doubt or change of chair, you must ask your distributor for confirmation. The compatibility guide is available on the website [www.eppur.eu](http://www.eppur.eu).

## **2. Propulsion and braking**

- Forward

drive The Dreeft wheels are moved forwards by moving the handrim forwards. When moving forward, actuation is direct, ie similar to a conventional wheel.

- Coasting

During a forward trajectory, the handrim can remain stationary in relation to the chair without preventing the chair from moving forward. The freewheel position of the handrail induces a few centimeters "empty" play which does not activate either the forward gear or the brake.

- Braking

During forward movement, a force exerted on the handrim in the direction of reverse travel activates the braking system of the wheel. The deceleration is proportional to the force exerted by the user backwards.

- Backing

up Once the wheelchair is stationary, pushing backwards moves the wheels backwards.

The two wheels move independently to control the trajectory of the chair.

## **3. Mounting and removing Dreeft**

To mount the wheels on your chair:

1. Press the push button on the quick-release axle;
2. Check that you have the same color on the wheel pad and that of the centering pin of the adapter.
3. Insert the axle of the drive wheel into the positioning sleeve (axle barrel) of the wheelchair;
4. Turn the wheel until the centering pin of the adapter enters one of the holes in the daisy chain;
5. Check that the push button has come out;
6. Pull on the wheel to check that it is securely locked in the frame.



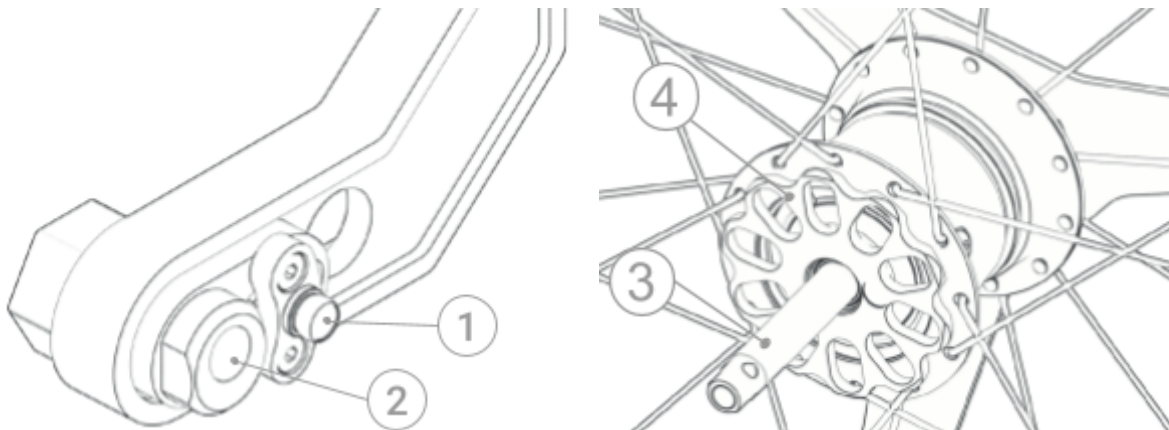

1. Centering
2. pin

3. Axle for quick disassembly of the drive wheel
4. Daisy of the hub

**⚠ Always check that the wheel is properly blocked by pulling it out after each assembly.**

**⚠ Put the right wheel on the right (yellow dot) and the left wheel on the left (blue dot). If the two wheels are reversed, the braking system does not work.**

#### **4. Installation of other wheel models once the chair is equipped with adapters**

**⚠** Once the chair is equipped with Dreeft adapters, other wheel models may become incompatible with the chair. To be able to continue using other wheels (such as the original wheelchair wheels, or mountain bike wheels), contact the distributor who sold the product to check compatibility and adapt them accordingly. mounting axles.

## **2) Use of the wheels**

### **1. Safety information**

The actuation of the wheels by the handrim is not direct as on a conventional wheel. The handling of the wheelchair is therefore totally different and it is necessary to practice in safe conditions before going outside.

### **2. First trips with a wheelchair fitted with Dreeft**

When using the wheels for the first time, practice on flat ground and with an accompanying person to ensure that the device is easy to handle.

The companion must remain at the back of the wheelchair to secure the user in the event of a fall while handling the device.

- **Forward** : Move the handrims forward to move forward.
- **Braking** : Move the handrims backwards to the stop, and pull until the wheelchair comes to a complete stop.

- **Reverse:** Move the handrim backwards until it stops, then continue to pull to reverse.
- **Obstacle passage:** Raise the front wheels to pass the obstacle. Watch out for backlash which can make static balance more difficult to maintain.

 Train **to get used to the game and not brake too suddenly.**

 **Never train on “two wheels” or over obstacles without an anti-tip wheel or without the help of an accompanying person in the back to catch people in the event of a fall.**

### 3) **maintenanceWheel**

Do not use aggressive detergents, solvents or hard brushes for cleaning. Clean the wheels with a non-aggressive cleaner and water. Quickly and thoroughly dry everything.

 **If the grease is washed or blown out of the ball bearings or the hub by compressed air, damage may occur.**

 **The pressure in the tires must be between 7 and 8 bars.**



### 4) **Transporting the wheels**

The wheels are removable in order to transport the wheelchair in a vehicle.

 **Be sure to limit shocks on the wheels during transport and transport them in suitable packaging.**

## IV. SAFETY

### 1) **Meaning of symbols**

-  Warning against possible risks of accidents and serious injuries.
-  Warning against possible risks of accidents and injuries.
-  Warning against possible technical damage.

### 2) **General safety information before using Dreeft wheels**

 **Risks incurred due to incorrect use of the product (loss of brake function, fall, tipping, etc.)**

**Situation:** Exceeding the duration of use, defective tire

Advice:

- One use of the product exceeding the duration of use indicated (5 years) leads to an increase in residual risks. In the following cases, stop using the device and contact your specialist retailer:
  - Poor braking
  - Breakage or problem with the adapters
  - Wheel runout
  - Broken
  - or deflated tire
  - Any unusual behavior of the handrim, the brake function
- When the of use is reached, the user or the person accompanying you are advised to contact the specialized personnel who carried out the adjustment of the wheels or the company's after-sales service. The user will be able to find out about the known risks and the current possibilities for refurbishing the product.
- Make sure the tires are not worn or damaged;
- Replace the tires in the event of damage, contact your specialist dealer to repair the wheels.

### 3) **General information on safety when using Dreeft**

#### ● **Trapped fingers**

**Situation:** trapped between the spokes and the flange when using the wheels, fingers trapped between the handrail and the rim during a side impact

#### Tips:

- Do not put your fingers between the spokes and the flange while using the wheel and while it is rotating.

#### ● **Risks incurred while driving (tilting, falling, impact)**

**Situation:** too suddenly, bad reflex due to braking habits, user not or not experienced, sudden acceleration, dangerous

#### braking

- driving use of Dreeft wheels present in this manual;
- Never use the device without an anti-tip wheel without mastering the 2 wheels. For learning 2 wheels: train in safe conditions with a retaining strap held by a trained third party;
- Learn to understand the wheels on your wheelchair with the self-training detailed in the instructions;
- Do not take slopes greater than 7° and/or the limit recommended by the wheelchair manufacturer. The system does not prevent the loss of grip on the ground which leads to a loss of the brake function;

### 4) **General information concerning safety during assembly of Dreeft wheels**

#### ● **Absence of verification of the assembly before use**

Tilting, falling, loss of the brake function

- During the first use, check that the wheels are properly engaged in the chassis, and that the axle is securely locked;
- Check that the right wheel and the left wheel are not reversed
- Check that the manual brakes are still functional on the wheel;
- Make sure the tire pressure is between 7 and 8 bar;

### ● Risks incurred if improper installation (non-functioning of the brake)

**Situation:** incorrect assembly of the adapter on the chassis / vice versa of the adapters, incorrect adjustment of the parking brake during assembly, error when removing / fitting the wheels, wrong choice of adapter (case when changing wheelchairs)

Advice:

- After installation, check that the wheel is functional by spinning the wheel in a vacuum and pulling the handrail backwards to activate the brake and stop wheel;
- Check that the wheels are completely fixed when the parking brakes are engaged;
- Read the assembly instructions explaining in detail the assembly instructions;

## V. MAINTENANCE

### 1) Safety information

Before each use, check the working condition of the Dreeft wheels.

In the event of a defect, the wheels must not be used. This prevails in the event of instability, loss of brake function or technical failure preventing the user from holding the road. Specialist personnel must be informed as soon as possible in order to correct the faults found.

If you notice any wear, deformation, damage or loosening of parts, contact specialized personnel (dealer or manufacturer).

The manufacturer recommends regular inspection of the wheels by specialist personnel every 12 months. This maintenance can be done at the same time as your wheelchair.

Lack of maintenance can cause serious injury and/or endanger the life of the user.

Only authorized personnel or the manufacturer are authorized to carry out repairs and maintenance of the product. If a repair is necessary, this will be carried out by the dealer if possible, otherwise the wheels will be sent to the manufacturer.

### 2) Maintenance

<i>schedule Check</i>	<i>Before use</i>	<i>Every month</i>	<i>Every 12 months</i>
Operation of parking brakes	X		

Check of tire pressure		X	
Operation of wheel brakes		X	
Damage to the handrim		X	
Check of the tension of the wheel spokes			X
Check of the adapters			X

**3) Identifying and repairing faults**

With a bit of manual skill, you (or an assistant) can maintain certain parts of your product and thus ensure that it operates perfectly:

- Check that the screws are tight, especially during first uses of the chair with Dreeft wheels or after making adjustments to the chair with wheels and adaptors. If a problem occurs, stop use immediately and contact the specialist dealer as soon as possible;
- The drive wheel system must be checked so that no dirt or dust gets on the wheel axle or in the axle barrel. Lightly lubricate the wheel shaft from time to time with a thin, resin-free oil (e.g. sewing machine oil) ;
- If the wheelchair gets wet, it is necessary to wipe it dry.

**VI. AFTER USE** 

**1) Disposal**

For disposal it is necessary to return the product to the specialist dealer. All product components must be disposed of in accordance with the provisions relating to environmental protection in force in the country concerned.

**VII. NOTES**

.....  
.....  
.....  
.....  
.....  
.....  
.....  
.....  
.....  
.....  
.....











